

Installation and Maintenance Manual

Shut-Off Valves and Sensor Valve Combo

Alert-1

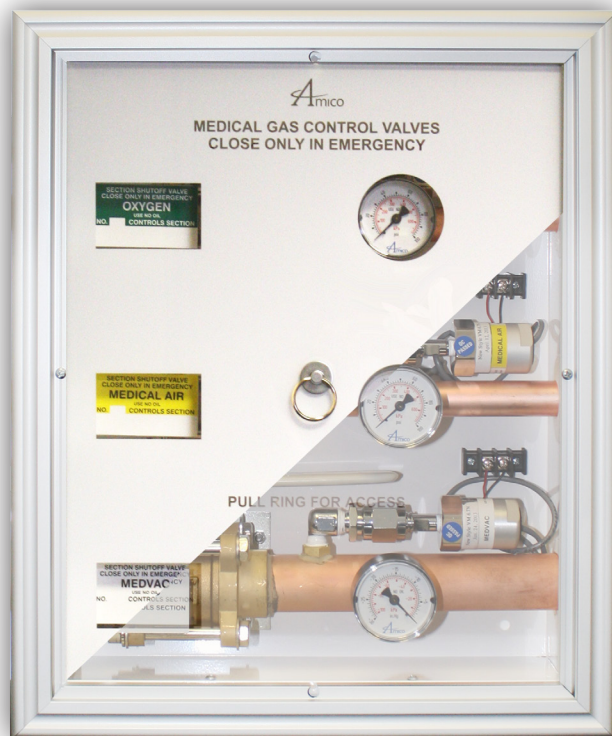

Table of Contents

Introduction	3
Medical Facility Responsibility	3
Precautions	3
Installation of Shutoff Valves	4
Installation of Valve Boxes	5 - 6
Maintenance	6
Repair Kit Part Numbers	7

Introduction

Amico Shutoff Valves are used to stop the flow of medical gas or vacuum in the medical gas distribution pipeline in cases of emergency or maintenance.

Valve Boxes must be installed to enclose the shutoff valves when the valves are located in areas accessible to unauthorized personnel.

The installation and maintenance should be conducted in accordance with the following standards:

NFPA 99C

CSA Z7396.1

Medical Facility Responsibility

Amico Shutoff Valves and Valve Boxes will perform in conformity with the descriptions contained in this manual and accompanying labels and/or inserts when assembled, operated, maintained and repaired in accordance with the instructions provided.

Shutoff Valves must be inspected periodically. A defective product should not be used. Parts that are broken, missing, plainly worn, distorted or contaminated should be replaced immediately. Should such repairs or replacements become necessary, please contact your local distributor.

Precautions

In this manual, please note these key words:



WARNING: used to denote steps which can prevent injury.

NOTE: used to point out helpful information.

Installation of Shutoff Valves

1. Shutoff Valves should be installed with handles pointing downstream for pressurized gases and upstream (towards the terminal or inlet side) for vacuum.
2. Before brazing, wrap wet rags around the tube extensions next to the valves to prevent overheating and possible damage to the valve seals. Connect copper tubing to the valve extensions using brazing materials and methods in accordance with NFPA 99 or CSA Z7396.1. Once valve extensions are cool, remove rags.
3. Test the systems (per appropriate standards) to ensure that the intended gas and vacuum services are connected to the appropriate lines.

 **WARNING:** Mis-connection of gases could lead to serious or fatal injury to patients. Following initial installation of shutoff valves, make certain that the intended services are correctly connected to the appropriate service lines.

4. Test the system for leaks (as per appropriate standards).

NOTE: Do not install gauges and sensors assembly before the leak test. Excessive pressure can damage the gauge and sensor. Pressure in the system will increase or decrease with temperature rise or fall.

If no leaks are found, gauges and sensor assembly (purchased separately) can be installed, if required. Pipe sealants should comply with requirements of NFPA 99 or CSA Z7396.1. Use care to exclude pipe sealants from the valve cavity and from interior tube surfaces exposed to medical gas flow or vacuum service. Properly applied Teflon tape is an alternative to pipe sealants. Check shutoff valve handle operation for proper clearance from gauge (if installed).

5. Each shutoff valve is supplied with an elbow (1/8" M x 1/4" F) to connect a DISS fitting (sensor provision valve only). The elbow is to be installed on site with the remote alarm sensor. Refer to "Installation of Alarm" in the Alarm Valve Combo Unit Alert-1 Installation and Maintenance Manual.

NOTE: DISS Demand check valves are provided with alarm.

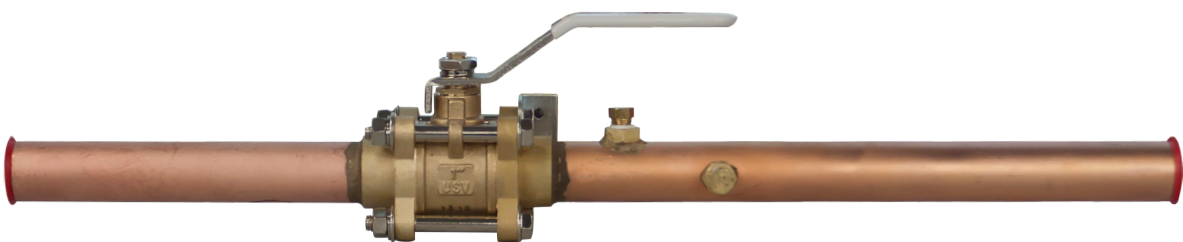

Installation of Valve Boxes

The Amico Sensor Valve Combo Valve Box is shipped in one container holding two separate packages. One package contains the valve box, valves and gauges (if required). The other package contains the window and the frame assembly.

1. **Recessed Valve Box:** The rough-in of the valve box arrives with a cardboard shield covering its front. You will need to remove the cardboard shield to install the rough-in and perform the pressure test, but it should be repositioned to protect the valves while the walls are being finished. Anchor the valve box rough-in to the studs so that the front edge will be flush or slightly recessed with the finished wall. The recommended mounting height is 66" (1676 mm) from the top of the valve box to the finished floor.

NOTE: The shutoff valve handles should be installed to point downstream for Pressurized Gases.

2. Before brazing, remove box plugs, they could melt during brazing, wrap wet rags around the tube extensions next to the valves to prevent overheating and possible damage to the valve seals. Connect copper tubing to the valve extensions (outside the valve box) using brazing methods and materials in accordance with NFPA 99 or CSA Z7396.1. Once valve extensions are cool, remove rags.
3. Test the system (per appropriate standards) to ensure that the intended gas and vacuum services are connected to the appropriate lines.

 **WARNING:** Mis-connection of the gases could lead to serious or fatal injury to patients. Following the initial installation of shutoff valves, make certain that the intended services are correctly connected to the appropriate service lines.

4. Test the system for leaks (as per appropriate standards).

NOTE: Do not install the gauges and sensor assembly before the leak test. Excessive pressure can damage the gauge and sensor. Pressure in the system will increase or decrease with temperature rise or fall.

If no leaks are found, gauges and sensor assembly (purchased separately) can be installed, if required. Pipe sealants should comply with requirements of NFPA 99 or CSA Z7396.1. Use care to exclude pipe sealants from the valve cavity and from interior tube surfaces exposed to medical gas flow or vacuum service. Properly applied Teflon tape is an alternative to pipe sealants. Check shutoff valve handle operation for proper clearance from gauge (if installed).

5. Each shutoff valve is supplied with an elbow (1/8" M x 1/4" F) to connect a DISS fitting (sensor provision valve only). The elbow is to be installed on site with the remote alarm sensor. Each sensor will have a terminal block, to connect the negative and positive wires. The terminal blocks shall be assembled into the valve box. Refer to "Installation of Alarm" in the Alarm Valve Combo Unit Alert-1 Installation and Maintenance Manual.
6. Mark the areas controlled by each valve on the labels enclosed. Attach the labels to the label holders.

Installation of Valve Boxes

 **WARNING:** Make certain that the proper label coincides with the valve it describes and is positioned on the label holder so that it can be easily read.

7. Recessed Valve Boxes: After the wall is finished, remove the cardboard shield (keep screws). Remove the window by pulling the ring towards you and attach the aluminum frame to the valve box with the No. 6 metal screws provided. After, put the window back in place.

Maintenance

Operate shutoff valves periodically and repair them, if seals tend to stick or leak. Notify all appropriate personnel before shutting off any gas supply.

 **WARNING: To protect the lives of patients, always notify the appropriate medical facility staff before shutting off the supply of medical gas or vacuum through a shutoff valve. Do not close shutoff valves except in cases of emergency or maintenance.**

Clean the exterior of the valve boxes routinely with soap and water. Strong solvents may damage the Lexan window.

Authorized hospital personnel should close shutoff valves in the event of fire, explosion or damage to the pipeline systems or equipment.

In Valve Boxes, the Shutoff Valve handles become accessible after the window has been removed from the valve box.

To remove the window, grasp the ring and pull outwards. Turn valve handle towards you to shut off the flow of gas or vacuum.

Zone Valves have a swingout design body which makes changing the internal components of the ball valve easier.

All valve bodies can be accessed by loosening all bolts and nuts and removing only one bolt, at this point the valve body can be swung out for servicing.

Repair Kit Part Numbers

Part Number	Size
V-X-RK-USV-05	1/2"
V-X-RK-USV-07	3/4"
V-X-RK-USV-10	1"
V-X-RK-USV-12	1-1/4"
V-X-RK-USV-15	1-1/2"
V-X-RK-USV-20	2"
V-X-RK-USV-25	2-1/2"
V-X-RK-USV-30	3"
V-X-RK-USV-40	4"

Repair Kit Consists of the Following:

- A) O-Ring
- B) Teflon Seat

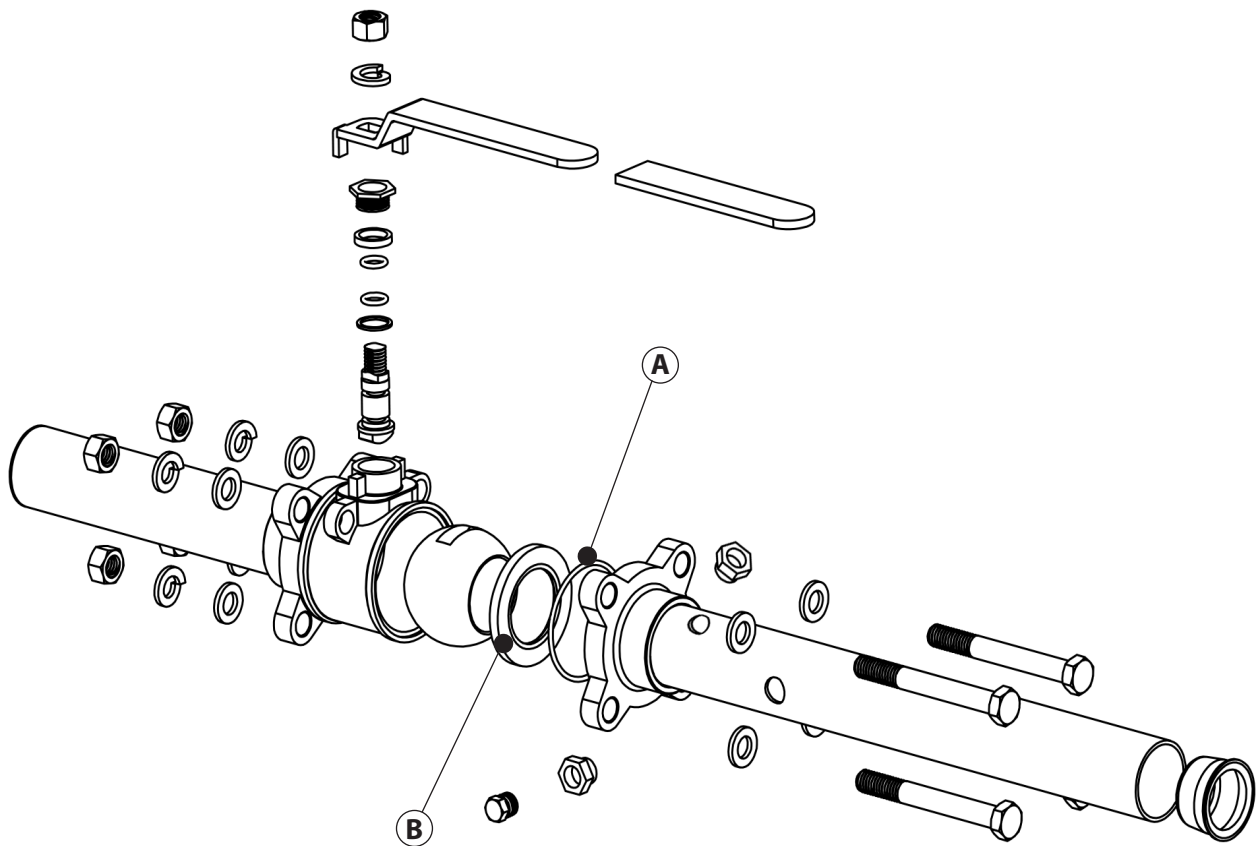

www.amico.com

Amico Pipeline | www.amico.com

85 Fulton Way, Richmond Hill
Ontario, L4B 2N4, Canada

71 East Industry Court, Deer Park
NY 11729, U.S.A.

Toll Free Tel: 1.877.462.6426

Toll Free Fax: 1.866.440.4986

Tel: 905.764.0800

Fax: 905.764.0862

Email: info@amico.com

