



O2 Manifold System Instruction Manual



WARNING

IMPORTANT:

READ MANUAL COMPLETELY BEFORE OPERATING THIS DEVICE

This manual contains instructions on periodically required checks to be performed by the user. These checks are necessary to ensure the proper performance of this device and its safety features.

RETAIN THIS MANUAL FOR FUTURE REFERENCE

CAUTION: Federal law requires this device for use by or on the order of a physician or dentist.

CAUTION: Do not attempt to repair or alter this device. Unauthorized repair, alteration or misuse of this device is likely to adversely affect the performance and will void the warranty.

CAUTION: Never oil or grease any part of this system.

Index

Alarm.....	11-15
Alarm Installation Diagram.....	13-15
Alarm Testing.....	12
Cylinder Restraint Installation.....	8
Dealer Instructions.....	17
Desk Alarm Installation.....	14-15
Existing Wall Installation.....	13-15
Exposed/Concealed Piping Installation.....	7-10
Inspection/Testing.....	16
Installation.....	6-15
Introduction.....	4
Manifold.....	7-8
Manifold Packages.....	5
Manifold Piping Installation Diagram.....	9-10
Operation.....	20-21
Purchase Record.....	22
Rough-In Piping Installation.....	7-8
Service.....	18-19
Transformer Installation.....	12
Wall Alarm Installation.....	11-15
Warning.....	2
Warranty.....	23
Wiring.....	15

Introduction

The Belmed Manifold System conforms with the code requirements specified in NFPA 99, Category 3, and include the following code required features:

1. Pressure regulator set at 50-55 PSI installed on each cylinder
2. Flexible hose of 1000 PSI burst strength
3. Connection between regulator and piping system are approved Diameter Index Safety System (DISS)
4. Check Valve located down stream of each regulator
5. Pressure relief valve for each gas pipeline, set at 75 PSI, located downstream of each check valve
6. Restrainers to adequately secure cylinders from tipping
7. Audible and visual alarm for each gas pipeline, activated by an automatic pressure switch when pipeline pressure is less than 40 PSI or more than 65 PSI.

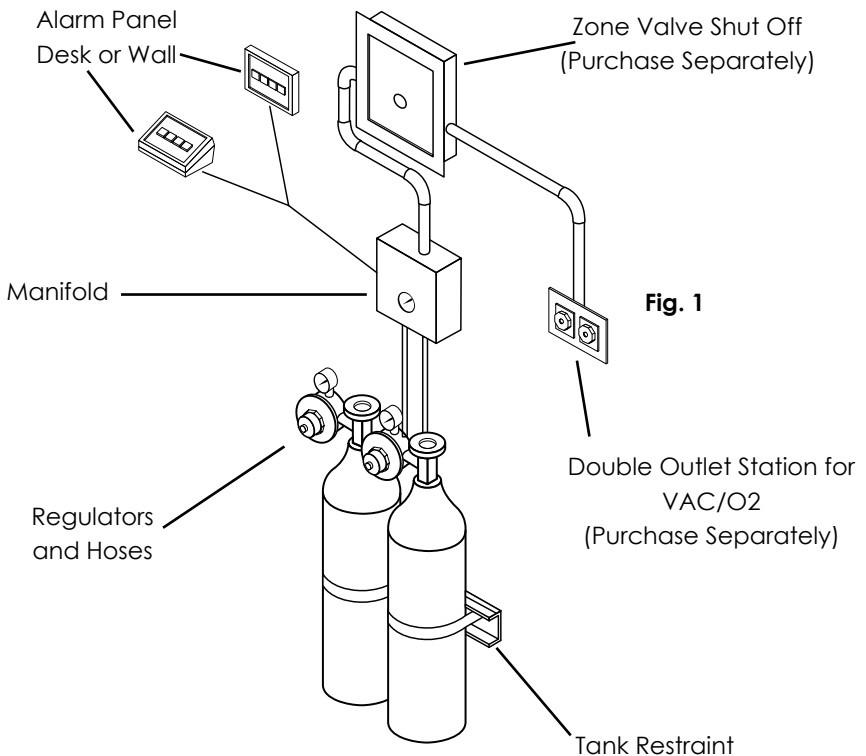

Manifold Packages

2 Oxygen Cylinders with Wall Alarm System

Part Number	Description
2020-W	Includes: Manifold, Alarm, Cables, Regulators, Hoses, Tank Restraints



2 Oxygen Cylinders with Desk Alarm System

Part Number	Description
2020-D	Includes: Manifold, Alarm, Cables, Regulators, Hoses, Tank Restraints



Installation

The Belmed Manifold is designed to be installed with fixed piping exposed or concealed, depending on wall construction. Manifold attaches to wall with four (4) #10 fasteners.

Piping

Belmed Manifold systems utilize CROSSGUARD SAFETY SYSTEM which is designed to prevent cross-connections between nitrous oxide and oxygen by eliminating common sizes. The Belmed Manifold is supplied with 1/2" O.D. tubing pipeline connector for oxygen. The pipeline connector attaches to the manifold with a DISS nut. THE EMPLOYMENT OF THE DIAMETER INDEXED COPPER TUBING MUST BE INSTALLED THROUGHOUT THE ENTIRE PIPING SYSTEM.

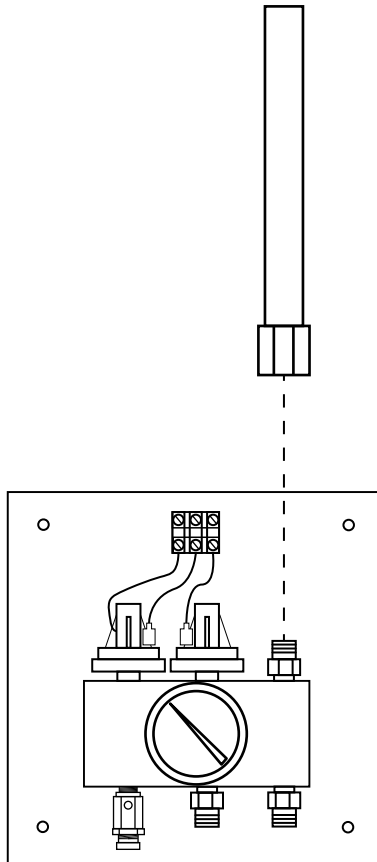

Fig. 2

Manifold

Manifold cover attaches via tongue and groove arrangement. To attach align cover over gauge and push down to remove cover, place thumbs on the inside of the cover and push outward slightly while lifting.

Manifold should be installed so that bottom edge is five (5) feet above floor line. Hold manifold so bottom edge is at five feet (5ft). Mark four (4) holes. Secure with #10 fasteners making sure manifold is level. If piping is to be concealed, also mark hole for cutout area of mounting panel. Remove manifold and complete all hole drilling.

EXPOSED PIPING INSTALLATION:

Secure manifold to wall as described in previous paragraph. Remove dust covers from DISS male outlet connectors and moderately tighten pipeline connector to manifold. Each pipeline connector to fixed piping and silver solder. Refer to figure #3. NOTE: Do not allow dust or other debris to enter manifold block.

CONCEALED PIPING INSTALLATION:

Drill 2" diameter hole for concealed piping. Cut pipeline connector 1" above DISS nuts and elbow connectors to suitable lengths of piping and silver solder fittings/piping. (Refer to figure #3). Allow vertical riser line to hang loosely for later manifold attachment. Note: Do not allow dust or debris to enter manifold block.

Manifold (continued)

ROUGHED IN PIPING INSTALLATION:

If studs are in place but walls not erected, install pipelines as previously described (for either concealed or exposed piping). The bottom edge of DISS nuts on pipeline connectors should be $6\frac{1}{2}$ " (see figure 4) above floor line. Allow vertical risers to hang loosely to provide some play in lines to attach DISS fittings to manifold. PROVIDE INFORMATION FOR DRYWALL INSTALLER WITH HOLE DIMENSIONS. (ONE - 2" DIA. HOLES, $6\frac{1}{2}$ " (see figure 4) ABOVE FLOOR).

COMPLETE REST OF PIPELINE INSTALLATION, WHEN COMPLETELY INSTALLED, PERFORM REQUIRED PRESSURE TEST AND CROSS LINE CHECK (see page #2) PURGE PIPELINE SYSTEM WITH INTENDED GAS.

CYLINDER RESTRAINT INSTALLATION:

Always secure bracket 40" above floor line

Dimensions and hole placement shown use $\frac{5}{16}$ " (9mm) wall mounting hardware with washers appropriate for wall construction. Concrete anchor bolts (at least 2 1/2" long) for concrete and concrete block. Wood screws and flat washers for wood, or appropriate size drywall anchors. Attach chain to complete installation. Use 2 fasteners for cylinder bracket.

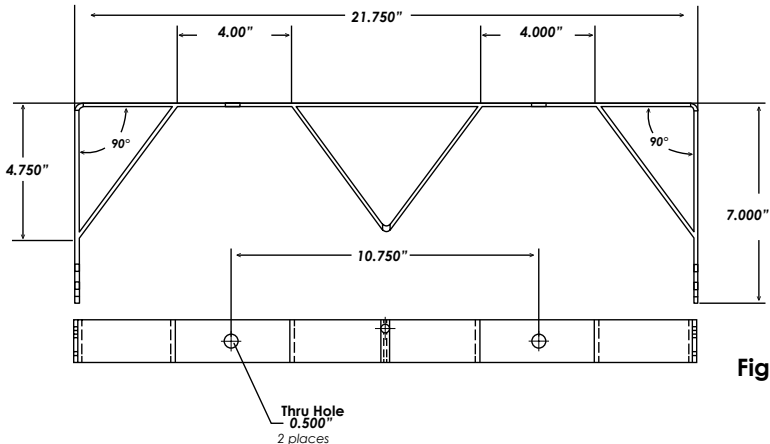

Fig. 3

CONNECT REGULATORS AND HOSES (see page 18 for regulator adjustment)

Manifold Installation

Concealed Piping

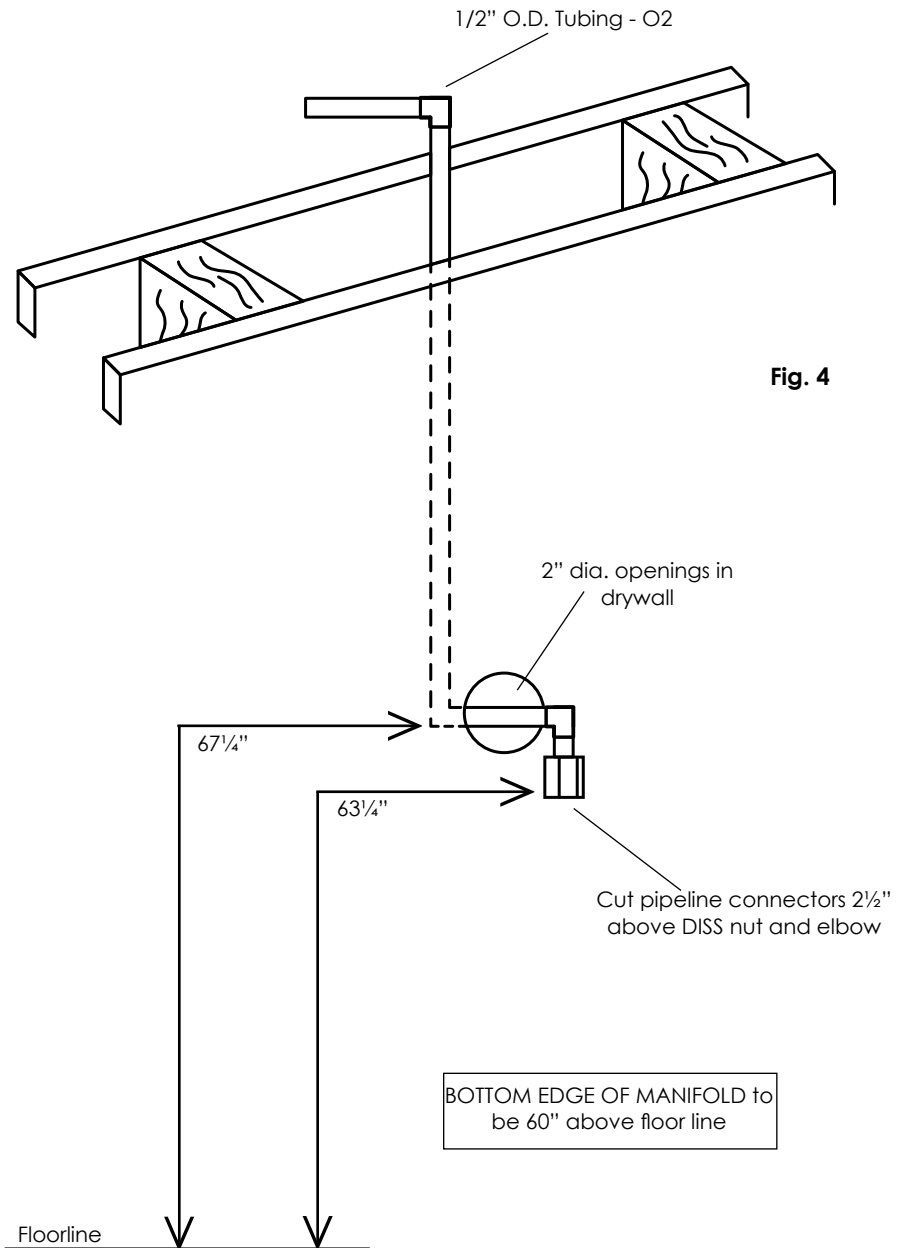

Fig. 4

Manifold Installation

Exposed Piping

CYLINDER ROOM CONSTRUCTION

1. Separate room or cabinet
2. 1½ hr fire rating
3. Door must lock
4. Room vented, min. 72 sqft
5. Cylinders restrained
6. Do not use room for compressors. Storage of flammable materials or other equipment

NOTE: 24 hr/150 PSI pressure test may be put on manifold. Use supplied relief plugs to close off relief valves during test. REMOVE PLUGS AFTER TEST.

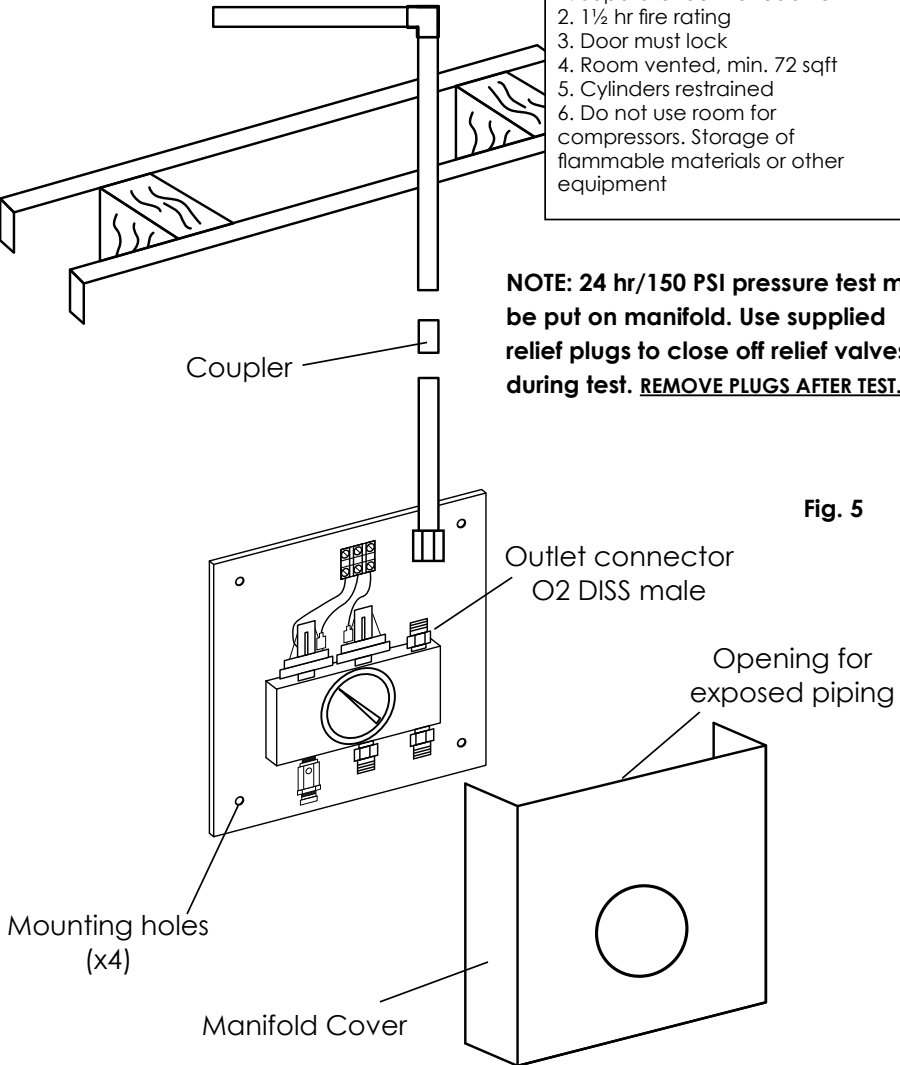

Fig. 5

Alarm

DESK STYLE ALARM INSTALLATION:

Route manifold and transformer cables shown on page 14. Route all wires through hole in rear of case. Remove terminal plug from alarm and wire per page 14. Attach upper and lower case with four (4) supplied screws. Special Note: desk alarm may be supplied with plug in type AC adapter instead of remote transformer. To install AC plug in adapter, attach adapter wires to terminals #4 and 5 of alarm and plug into nearest receptacle. Test Alarm.

NEW WALL STYLE ALARM INSTALLATION:

Attach 3-gang electrical box to studs at a point 5ft above floor line. (studs must be in 16" centers). Gang box has mounting bracket and clamp for easy attachment to studs (nail to wood studs, sheet metal screw to aluminum studs). Gang box must be mounted level and installed in ensure alarm will be flush to finished wall surface. Depth gauge markings are located on side of box for 3/8", 1/2" and 5/8" wall thickness. We recommend gang box be installed slightly below flush to finished wall surface. Route manifold and transformer cables through gang box, remove approximately 6" of cable cover from wiring and strip about 1/2" from each wire end. Clamp cable to gang box with clamp inside box. (Clamp may have to be moved). To attach wires to alarm, remove terminal plug from alarm and attach stripped wire ends to proper terminal (see figure 9). Reconnect plug to alarm, align pins on alarm with holes in gang box and slide alarm into gang box until alarm is flush with wall surface. Test alarm.

Alarm (continued)

EXISTING WALL INSTALLATION:

Wall style alarm may be installed in existing walls when walls are hollow and there are drop ceilings or otherwise accessible areas to route cables. Remove mounting bracket from gang box by drilling out rivets with a 1/4" drill bit. Remove clamp. Attach the two metal tabs supplied with gang box to the center top and bottom positions on front of gang box. (Attach tabs so that indentations are inside and facing to rear of gang box). Cut an opening 5³/₄"W x 3⁷/₈"H in wall at desired alarm site. Attach gang box into opening with switch box supports (Madison Straps) which are installer supplied. Route manifold and transformer cables through gang box, remove approximately 6" of cable cover from wiring and strip about 1/2" from each wire end. Clamp cable to gang box with clamp inside box. (Clamp may have to be moved). To attach wires to alarm, remove terminal plug from alarm and attach stripped wire ends to proper terminal (see figure 6). Reconnect plug to alarm, align pins on alarm with holes in gang box and slide alarm into gang box until alarm is flush with wall surface. Test alarm.

TRANSFORMER INSTALLATION:

Remote transformer is designed to connect to a 4" x 4" junction box with a 120 volt AC supply. Connect the 120 volt primary side of transformer to 120 Vac supply with wire nuts. Connect the 12 volt AC secondary side of transformer to the 2 conductor wires of alarm cable with wire nuts. Secure cover to junction box. Transformer must be mounted OUTSIDE junction box. Refer to the diagram on page 14. (See special note under desk alarm instructions regarding the optional plug in AC adapter type transformer).

ALARM TEST:

Refer to page 17 of manual for alarm test instructions. Note: if pipeline system and gas tanks are not installed, pressure switch contacts on manifold may be bridged to determine alarm circuit is connected properly. Alarm test procedure described on page 17 must still be performed after the system is completely installed.

Alarm Installation

Wall Alarm

3 Gang Electric box w/ clamps & mounting bracket. Mount to be flush with finished wall. Height is 5ft above floor line. May also be mounted in some existing walls.

3 conductor cable route to manifold

2 conductor cable route to transformer

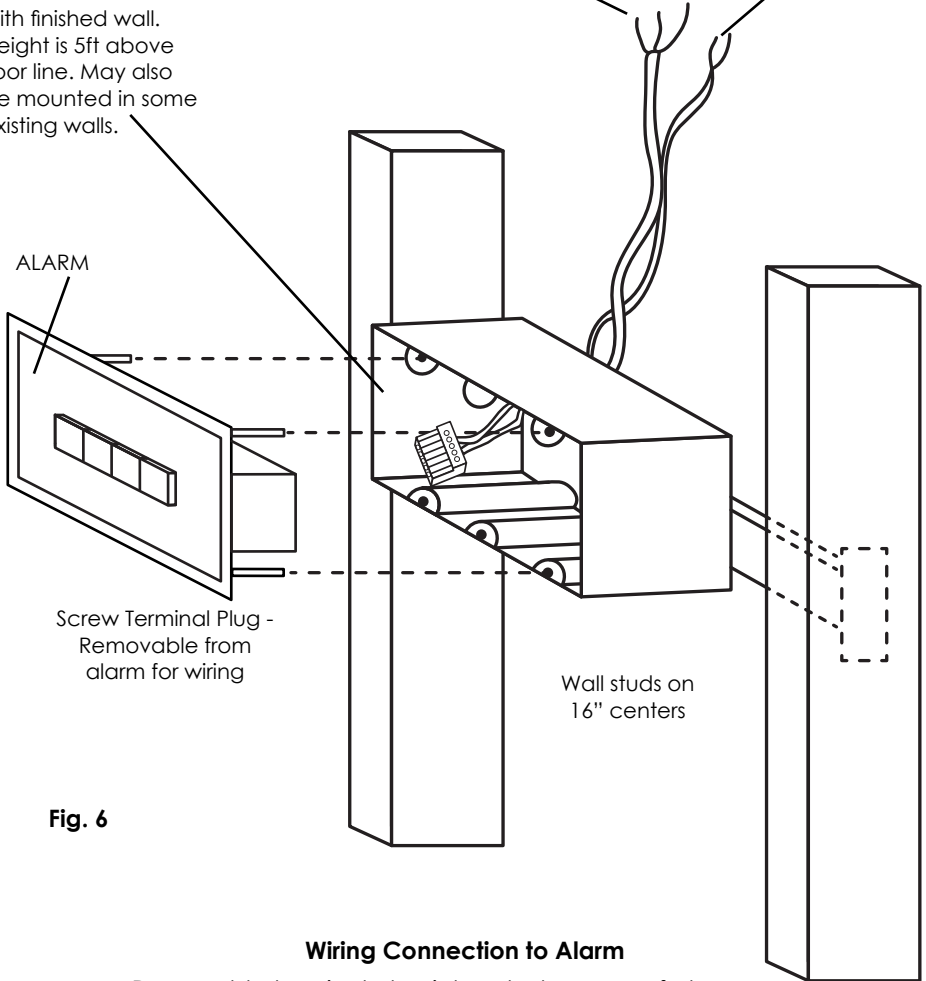

ALARM

Screw Terminal Plug -
Removable from
alarm for wiring

Wall studs on
16" centers

Fig. 6

Wiring Connection to Alarm

Removable terminal plug is located on rear of alarm. Pull to right to remove from socket. Attach wires from manifold & transformer to proper screw terminals of plug and reconnect to alarm socket. Terminal NOS.: #1-O2 HI (red) #2-O2 LO (green) #3-COM (black)

Alarm Installation

Desk Alarm

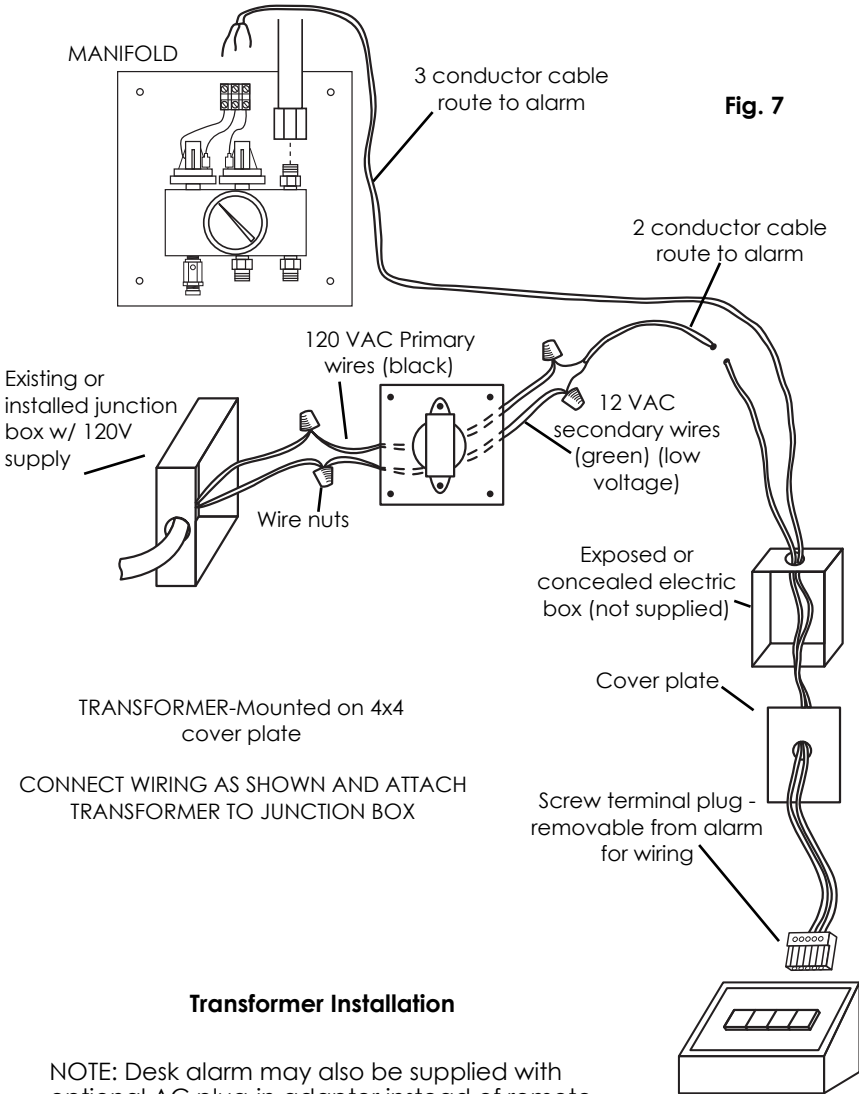

Manifold Wiring

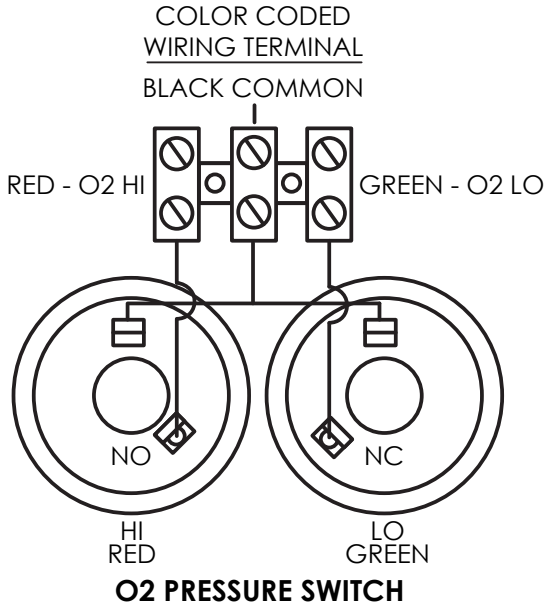

Fig. 8

Connect the three conductor wire to the terminal strip in the Manifold. Make sure to connect the proper wire to each terminal using the provided color code system

Alarm Wiring

Connect the two conductor wire to the plug adapter using terminals 4 & 5. Connect the five conductor wire to the plug adapter using the provided color code system.

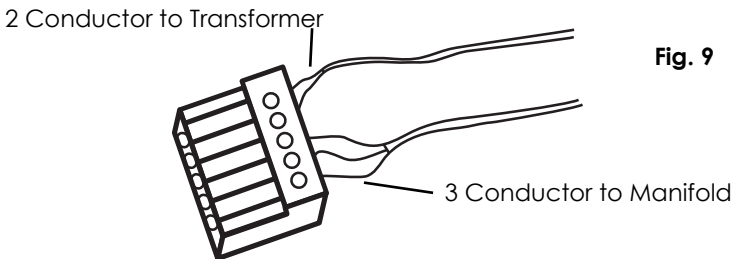

Fig. 9

Inspection

TESTING:

PRESSURE TEST:

After installation, each pipeline system must be tested for leakage using dry nitrogen at 150 PSI for 24 hours. Each joint should be checked with soapy water or an approved type leak detector.

CROSSLINE TEST:

Each gas pipeline MUST be checked to determine that no cross connections have been made. Reduce pipeline pressure to zero and then pressurizing one pipeline to 50 PSI using gas intended for that pipeline. Check each outlet station to determine that gas is being dispensed only from the pipeline being tested.

TEST PROCEDURES MUST BE PERFORMED AND ARE VITAL FOR THE SAFE OPERATION OF SYSTEM AS WELL AS YOUR OWN PROTECTION.

NOTE: The Belmed Manifold is designed to accept the 24 hr/150 PSI pressure test. Relief valve plugs are supplied with each manifold. Plugs are attached to chain and tag, do not disassemble. To plug relief valves, screw plugs into the ends of both relief valves. DO NOT OVERTIGHTEN, a gentle finger tightening is sufficient to prevent valve seat from lifting during test. REMOVE PLUGS AFTER TEST.

Dealer Instructions

1. VERIFY THAT SYSTEM HAS BEEN LEAK TESTED, CROSSLINE.
2. INSTALL COVER PLATES ON OUTLET STATIONS
3. INSTALL SECONDARY EQUIPMENT (flowmeters, mounting brackets, etc)
4. TEST ALARM AND ADJUST REGULATORS
 - a. remove cap nut located on front of regulator
 - b. turn on alarm
 - c. establish 5 liter flow of oxygen on flowmeter
 - d. turn adjustment screw on regulator counter clockwise until line pressure is just below 40 PSI
 - e. oxygen "LO" indicator light and audio signal should come on, depress reset button to cancel audio signal
 - f. turn adjustment screw clockwise until line pressure is just about 65 PSI
 - g. oxygen "HI" indicator light and audio signal should come on, depress reset button to cancel audio signal
 - h. adjust oxygen pressure back to 50 PSI
 - i. adjust other oxygen regulator(s) to 50 PSI if required
 - j. replace cap nuts on regulators
6. PLACE INSTRUCTION MANUAL AND OPERATION INSTRUCTIONS ON WALL NEXT TO MANIFOLD
7. ENSURE WARRANTY CARDS ARE COMPLETED AND RETURNED TO BELMED
8. DEMONSTRATE SYSTEM TO DOCTOR

Service

NOTE: With exception of bulb replacement, all service on manifold system should be performed by a qualified, experienced service person ONLY.

REGULATOR ADJUSTMENT

Regulator line pressure should be 50 PSI at full cylinder pressure. Regulators should be adjusted with gas flowing. Connect gas machine to gas pipeline and establish a 3 LPM flow. Remove cap nut located on front of regulator. Turn clockwise to increase pressure and counter clockwise to decrease pressure. (see figure 10)

PRESSURE SWITCH ADJUSTMENT

NOTE: Top view drawing of Pressure Switch on right shows both high (NO) terminal and low (NC) terminal for illustration purposes only. Pressure switches on manifold will have only one terminal, either high (NO) or low (NC). First remove soft rubber cover from center of switch by gently prying off with small flat bladed screwdriver (or similar tool). This will allow access to 7/32" hex socket. Replace cover after adjustment. (see figure 11)

HIGH PRESSURE ADJUSTMENT (normally open terminal)

Turn Allen wrench **RIGHT** to **INCREASE** pressure
Turn Allen wrench **LEFT** to **DECREASE** pressure.

LOW PRESSURE ADJUSTMENT (normally closed terminal)

Turn **RIGHT** to **INCREASE** setting.
Turn **LEFT** to **DECREASE** setting

NOTE: Right indicates clockwise direction and left counter clockwise.

Color coding; RED – O2 HI, GREEN – O2 LO, BLACK – COMMON (Figure 8)

Regulator Adjustment

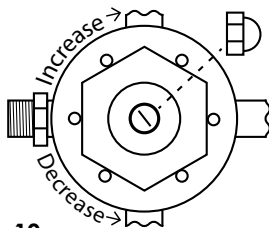

Fig. 10

Pressure Switch Adjustment

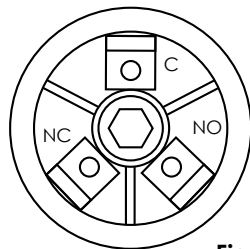

Fig. 11

Service

RELIEF VALVE

Valve must be reset to 75 PSI relief after servicing

IF A PROBLEM EXIST IT IS RECOMMENDED ENTIRE VALVE BE REPLACED (see figure 12)

ALARM BULB REPLACEMENT

A spare bulb is located within reset button housing disconnect alarm from power source. Gently pull on reset and expose housing. A tweezer type tool or someone with small fingers can remove bulb by gently pulling toward you. Replacement bulb #: 7382 (see figure 13)

Fuse Replacement: Fuse is located at right rear of alarm. Replace with 20mm – 0.5 amp fuse.

Relief Valve

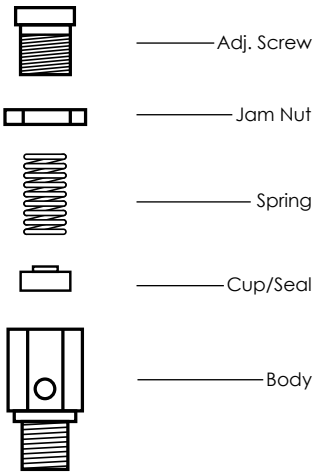

Fig. 12

Alarm Bulb Replacement

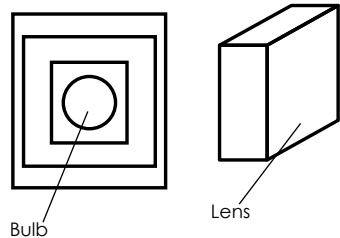

Fig. 13

Operation

NORMAL OPERATION:

AT the start of each work day, open all cylinder valves for each gas. CAUTION: OPEN CYLINDER VALVES SLOWLY. If more than one cylinder for a gas, read cylinder pressure on each regulator gauge and close those cylinders with the highest pressure. This will leave only the cylinder with the lowest pressure open and maintaining the fullest cylinders in reserve. Your gas supplier will supply tags to identify the “in use” and “reserve” cylinders. After turning on proper cylinders, observe line pressure gauge for each gas on manifold. Gauge indicator should be in the white area of dial between LO and HI (preferable at 50 PSI). After turning on cylinders and verifying correct line pressure, turn on gas supply alarm. Actuate “PUSH TO TEST” buttons to determine that audio and visual indicators are working normally. If during the work day, any cylinder becomes empty, the gas supply alarm will actuate a LO condition. When this occurs, depress reset button on alarm to cancel audio signal, open the reserve cylinder valve and reorder a replacement cylinder from gas supplier. The alarm will automatically reset when normal pressure is restored.

HIGH PRESSURE SIGNAL:

Indicates an abnormal pressure condition exists. Turn off system immediately and call a qualified service person.

NOTE: TURN OFF ALL CYLINDERS WHEN FACILITY IS UNATTENDED. Oxygen is a rapid accelerator of fire. With cylinder valves turned off, there is less danger in the event of an unrelated fire. This practice also provides for frequent checks on proper manifold operation and pressures.

Operation (continued)

RECORDING CYLINDER REPLACEMENT:

OXYGEN:

Replace cylinder when gauge on regulator reaches 200 PSI. The gauge will register approximately 2000 PSI when fully charged. Oxygen is in a gaseous phase within the cylinder. As the oxygen is used, the pressure indicated on regulator gauge will fall proportionally to the contents. (i.e.: 1500 PSI - 3/4 full, 1000 PSI - 1/2 full, etc.). Oxygen is generally supplied in "H" size cylinders and a fully charged cylinder contains 6909 liters of oxygen (244 cu. ft.)

NEVER ATTEMPT TO REPAIR OR MAKE CHANGES TO THE SYSTEM. IF IN DOUBT ABOUT PROPER OPERATION, A REPUTABLE SERVICE PERSON, EXPERIENCED WITH MANIFOLD SYSTEMS SHOULD BE CALLED AT ONCE

Purchase Record

MODEL NO.

SERIAL NO.

PURCHASE DATE

Notes

Warranty

Definition of Warranty Return: A product or part covered by the Belmed, Inc. warranty, that fails while the terms of the warranty are in effect.

THIS WARRANTY IS GIVEN IN PLACE OF ALL OTHER WARRANTIES, EXPRESSED OR IMPLIED, OF MERCHANTABILITY, FITNESS FOR A PARTICULAR PURPOSE OR OTHERWISE.

No statement or claim about the product by any employee, agent, representative or dealer of Belmed, Inc. shall constitute a warranty by Belmed, Inc. or give rise to any liability or obligation of Belmed, Inc.

Subject to the next sentence, Belmed, Inc warrants that each product or part shall be free from defects in workmanship and materials, under normal use and with appropriate maintenance, for one (1) year from the date of delivery to customer. For plastic, rubber and disposable parts or items Belmed, Inc. warrants only that each such part and item shall be free from defects in workmanship and materials at the time of delivery to the customer.

Belmed, Inc.'s obligation for breach of this warranty, or for negligence or otherwise, shall be strictly and exclusively limited to Belmed Inc.'s choice of repair or replacement of the product or part. This warranty shall be void for any product on which the serial number has been altered, defaced or removed.

Belmed, Inc. shall not be liable for any damage, injury or loss arising out of the use of the product, whether as a result of a defect in the product or otherwise, if, prior to such damage, injury or loss, the product was (1) damaged, misused, or misapplied; (2) repaired, altered or modified by persons other than Belmed, Inc. (3) not installed in strict compliance with applicable codes and ordinances; or (4) not installed by Belmed, Inc. or an authorized Belmed, Inc. dealer.

UNDER NO CIRCUMSTANCES SHALL BELMED, INC. BE LIABLE FOR INCIDENTAL OR CONSEQUENTIAL DAMAGES AS THOSE TERMS ARE DEFINED IN THE UNIFORM COMMERCIAL CODE.

Important: Traceability/Warranty Registration

Medical device legislation of 1976 mandates traceability of this equipment. Please fill out and return warranty card.



Order:

orders@belmedinc.com

Fax: 717-246-7586

Mail To:

PO Box 247

Red Lion, PA

Ship To:

887 Delta Rd

Red Lion, PA

Contact Us:

Local: 717-246-5500

Toll Free 888-723-5893

bmi@belmedinc.com

Tech Support:

help@belmedinc.com

www.belmedinc.com